

PERMIT NO.: _____

OWNERS NAME: _____

PROJECT LOCATION: _____

To be Completed and attached to the Building Permit Application Form

A. Roof

Roof Material _____
 Roof Sheathing _____
 Rafters _____ x _____ Spacing _____
 or Engineered Trusses _____ Spacing _____

B. Ceiling

Insulation _____
 Vapour Barrier _____
 Ceiling Joist _____ Spacing _____
 Ceiling Material _____

C. Walls

Double top plate
 _____ x _____ Studs at _____ on Center
 Single bottom plate
 Insulation _____
 Vapour Barrier _____
 Wall Sheathing _____
 Exterior wall finish _____
 Interior finish _____

D. Beam

_____ x _____ ply _____ x _____ species
 Supported at _____ on center
 _____ columns
 _____ x _____ x _____ footing

E. Foundation

_____ inch Concrete foundation wall at least _____ ft below grad
 Footing _____ wide _____ thick

F. Floor

_____ x underlay _____ sub floor
 _____ x _____ Joist at _____ on center Species Bridging at 7" on centre

G. Crawl Space

2" sand on 6 mil poly or equal
 Ventilation _____
 Insulation _____

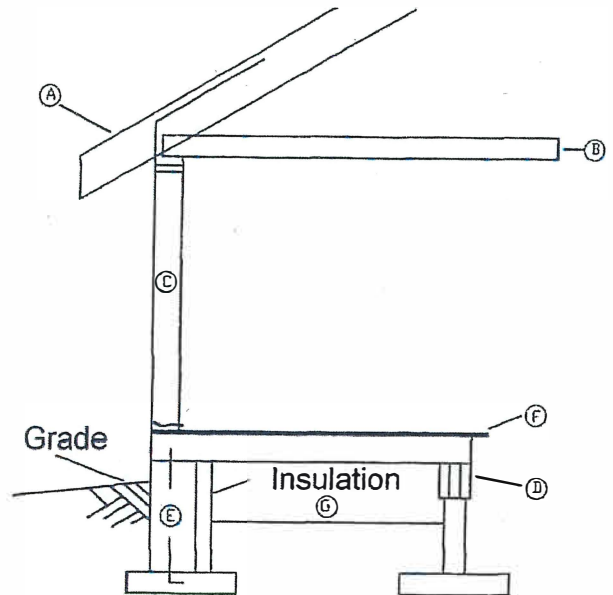

Comments: